

CONTENDER

STEP UP TO THE PLATE

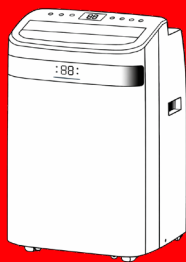

CONTENDER PORTABLE AIR CONDITIONER

AAC009



CONTENTS

1. BEFORE YOU BEGIN	3
2. FOR YOUR SAFETY	4
3. PRODUCT OVERVIEW	7
4. INSTALLATION	8
5. OPERATION	11
6. CLEANING AND CARE	15
7. TROUBLESHOOTING	16
8. DECOMMISSIONING	17
9. WARRANTY TERMS	18





I. BEFORE YOU BEGIN

I.1. PRODUCT DESCRIPTION

OUR POWERFUL PORTABLE AIR CONDITIONERS ARE GREAT COOLING SOLUTIONS FOR SINGLE ROOMS, CREATING A COMFORTABLE ATMOSPHERE IN YOUR SPACE. IT ALSO HAS VENTILATION AND DEHUMIDIFYING FUNCTION FOR CIRCULATING AIR AND REMOVAL OF MOISTURE. THEY'RE SELF-CONTAINED SYSTEMS THAT DO NOT REQUIRE ANY PERMANENT INSTALLATION ALLOWING YOU TO MOVE TO THE SPACE IN WHICH IT IS MOST NEEDED. THEY'RE COMMONLY USED IN KITCHEN, TEMPORARY-RESIDED, COMPUTER ROOMS, GARAGES, AND MANY OTHER PLACES WHERE INSTALLATION OF AIR-CONDITIONER OUTDOOR UNIT IS LIMITED.

THE ENVIRONMENTALLY FRIENDLY R290 IS USED AS THE REFRIGERANT. R290 HAS NO DAMAGING INFLUENCE ON THE OZONE LAYER (ODP), A NEGLIGIBLE GREENHOUSE EFFECT (GWP) AND IS AVAILABLE WORLDWIDE. BECAUSE OF ITS EFFICIENT ENERGY PROPERTIES, R290 IS HIGHLY SUITABLE AS A COOLANT FOR THIS APPLICATION. SPECIAL PRECAUTIONS MUST BE TAKEN INTO CONSIDERATION DUE TO THE COOLANT'S HIGH FLAMMABILITY.

I.2. SYMBOLS FROM THE UNIT AND USER MANUAL

SYMBOL	DESCRIPTION
 warning	THIS UNIT USES A FLAMMABLE REFRIGERANT. IF REFRIGERANT LEAKS AND COMES IN CONTACT WITH FIRE OR HEATING PART, IT WILL CREATE HARMFUL GAS AND THERE IS RISK OF FIRE.
	READ THE USER MANUAL CAREFULLY BEFORE OPERATION.
	FURTHER INFORMATION IS AVAILABLE IN THE USER MANUAL, SERVICE MANUAL, AND THE LIKE.
	SERVICE PERSONNEL ARE REQUIRED TO CAREFULLY READ THE USER MANUAL AND SERVICE MANUAL BEFORE OPERATION.

THE FOLLOWING SHOULD ALWAYS BE OBSERVED FOR SAFETY:

- THIS APPLIANCE IS INTENDED TO BE USED BY EXPERT OR TRAINED USERS IN SHOPS, IN LIGHT INDUSTRY AND ON FARMS, OR FOR COMMERCIAL USE BY LAY PERSONS.
- THIS APPLIANCE CAN BE USED BY CHILDREN AGED FROM 8 YEARS AND ABOVE AND PERSONS WITH REDUCED PHYSICAL, SENSORY OR MENTAL CAPABILITIES OR LACK OF EXPERIENCE AND KNOWLEDGE IF THEY HAVE BEEN GIVEN SUPERVISION OR INSTRUCTION CONCERNING USE OF THE APPLIANCE IN A SAFE WAY AND UNDERSTAND THE HAZARDS INVOLVED. CHILDREN SHALL NOT PLAY WITH THE APPLIANCE. CLEANING AND USER MAINTENANCE SHALL NOT BE MADE BY CHILDREN WITHOUT SUPERVISION.

- THE UNIT IS DESIGNED ONLY FOR USE WITH R-290 (PROPANE) GAS AS THE DESIGNATED REFRIGERANT.
- THE REFRIGERANT LOOP IS SEALED. ONLY A QUALIFIED TECHNICIAN SHOULD ATTEMPT TO SERVICE!
- DO NOT DISCHARGE THE REFRIGERANT INTO THE ATMOSPHERE.
- R-290 (PROPANE) IS FLAMMABLE AND HEAVIER THAN AIR.
- IT COLLECTS FIRST IN LOW AREAS BUT CAN BE CIRCULATED BY THE FANS.
- IF PROPANE GAS IS PRESENT OR EVEN SUSPECTED, DO NOT ALLOW UNTRAINED PERSONNEL TO ATTEMPT TO FIND THE CAUSE.
- THE PROPANE GAS USED IN THE UNIT HAS NO ODOUR.
- THE LACK OF SMELL DOES NOT INDICATE A LACK OF ESCAPED GAS.
- IF A LEAK IS DETECTED, IMMEDIATELY EVACUATE ALL PERSONS FROM THE STORE, VENTILATE THE ROOM AND CONTACT THE LOCAL FIRE SERVICE TO ADVISE THEM THAT A PROPANE LEAK HAS OCCURRED.
- DO NOT LET ANY PERSONS BACK INTO THE ROOM UNTIL THE QUALIFIED SERVICE TECHNICIAN HAS ARRIVED AND THAT TECHNICIAN ADVISES THAT IT IS SAFE TO RETURN TO THE ROOM.
- NO OPEN FLAMES, CIGARETTES OR OTHER POSSIBLE SOURCES OF IGNITION SHOULD BE USED INSIDE OR IN THE VICINITY OF THE UNITS.
- COMPONENT PARTS ARE DESIGNED FOR PROPANE AND NON-INCENDIVE AND NON-SPARKING. COMPONENT PARTS SHALL ONLY BE REPLACED WITH IDENTICAL REPAIR PARTS.

FAILURE TO ABIDE BY THIS WARNING COULD RESULT IN AN EXPLOSION, DEATH, INJURY AND PROPERTY DAMAGE.

2. FOR YOUR SAFETY



WARNING

PLEASE READ THIS MANUAL CAREFULLY AND FULLY UNDERSTAND BEFORE OPERATING YOUR APPLIANCE. YOUR SAFETY IS THE MOST IMPORTANT THING TO US.

2.1. OPERATIONAL PRECAUTIONS

- IF THE SUPPLY CORD IS DAMAGED, IT MUST BE REPLACED BY THE MANUFACTURER, ITS SERVICE AGENT OR SIMILARLY QUALIFIED PERSONS IN ORDER TO AVOID A HAZARD.
- THE APPLIANCE SHALL BE DISCONNECTED FROM ITS POWER SOURCE DURING SERVICE.
- ALWAYS OPERATE THE UNIT FROM A POWER SOURCE OF EQUAL VOLTAGE, FREQUENCY AND RATING AS INDICATED ON THE PRODUCT IDENTIFICATION PLATE.
- ALWAYS USE A POWER OUTLET THAT IS GROUNDED.
- UNPLUG THE POWER CORD WHEN CLEANING OR WHEN NOT IN USE.
- DO NOT OPERATE WITH WET HANDS. PREVENT WATER FROM SPILLING ONTO THE UNIT.
- DO NOT IMMERSE OR EXPOSE THE UNIT TO RAIN, MOISTURE OR ANY OTHER LIQUID.
- DO NOT LEAVE THE UNIT RUNNING UNATTENDED. DO NOT TILT OR TURN OVER THE UNIT.
- DO NOT UNPLUG WHILE THE UNIT IS OPERATING.
- DO NOT UNPLUG BY PULLING ON THE POWER CORD.

- DO NOT USE AN EXTENSION CORD OR AN ADAPTER PLUG.
- DO NOT PUT OBJECTS ON THE UNIT.
- DO NOT CLIMB OR SIT ON THE UNIT.
- DO NOT INSERT FINGERS OR OTHER OBJECTS INTO THE AIR OUTLET.
- DO NOT TOUCH THE AIR INLET OR THE ALUMINUM FINS OF THE UNIT.
- DO NOT OPERATE THE UNIT IF IT IS DROPPED, DAMAGED OR SHOWING SIGNS OF PRODUCT MALFUNCTION.
- DO NOT CLEAN THE APPLIANCE WITH ANY CHEMICALS.
- ENSURE THE UNIT IS FAR AWAY FROM FIRE, INFLAMMABLE, OR EXPLOSIVE OBJECTS.
- THE UNIT SHALL BE INSTALLED IN ACCORDANCE WITH NATIONAL WIRING REGULATIONS.
- DO NOT USE MEANS TO ACCELERATE THE DEFROSTING PROCESS OR TO CLEAN, OTHER THAN THOSE RECOMMENDED BY THE MANUFACTURER.
- THE APPLIANCE SHALL BE STORED IN A ROOM WITHOUT CONTINUOUSLY OPERATION SOURCES (FOR EXAMPLE: OPEN FLAMES, AN OPERATING GAS APPLIANCE OR AN OPERATING ELECTRIC HEATER).
- THE APPLIANCE SHALL BE STORED SO AS TO PREVENT MECHANICAL DAMAGE FROM OCCURRING.
- DO NOT PIECE OR BURN, EVEN AFTER USE.
- BE AWARE THAT REFRIGERANTS MAY NOT CONTAIN AN ODOUR.
- PIPE-WORK SHALL BE PROTECTED FROM PHYSICAL DAMAGE AND SHALL NOT BE INSTALLED IN AN UNVENTILATED SPACE, IF THAT SPACE IS SMALLER THAN 11 M².
- COMPLIANCE WITH NATIONAL GAS REGULATIONS SHALL BE OBSERVED.
- KEEP ANY REQUIRED VENTILATION OPENINGS CLEAR OF OBSTRUCTION.
- THE APPLIANCE SHALL BE STORED IN A WELL-VENTILATED AREA WHERE THE ROOM SIZE CORRESPONDS TO THE ROOM AREA AS SPECIFIED FOR OPERATION.



WARNING

ANY PERSON WHO IS INVOLVED WITH WORKING ON OR BREAKING A INTO A REFRIGERANT CIRCUIT SHOULD HOLD A CURRENT VALID CERTIFICATE FROM AN INDUSTRY-ACCREDITED ASSESSMENT AUTHORITY, WHICH AUTHORISES THEIR COMPETENCE TO HANDLE REFRIGERANTS SAFELY IN ACCORDANCE WITH AN INDUSTRY, RECOGNISED ASSESSMENT SPECIFICATION.



WARNING

SERVICING SHALL ONLY BE PERFORMED AS RECOMMENDED BY THE EQUIPMENT MANUFACTURER. MAINTENANCE AND REPAIR REQUIRING THE ASSISTANCE OF OTHER SKILLED PERSONNEL SHALL BE CARRIED OUT UNDER THE SUPERVISION OF THE PERSON COMPETENT IN THE USE OF FLAMMABLE REFRIGERANTS.

IF YOU DON'T UNDERSTAND SOMETHING OR NEED HELP, PLEASE CONTACT YOUR DEALER.

2.2. SAFETY PRECAUTIONS ON SERVICING

PLEASE FOLLOW THESE WARNINGS WHEN TO UNDERTAKE THE FOLLOWING WHEN SERVICING AN APPLIANCE WITH R290.

2.2.1. CHECKS TO THE AREA

PRIOR TO BEGINNING WORK ON SYSTEMS CONTAINING FLAMMABLE REFRIGERANTS, SAFETY CHECKS ARE NECESSARY TO ENSURE THAT THE RISK OF IGNITION IS MINIMISED. FOR REPAIR TO THE REFRIGERATING SYSTEM, THE FOLLOWING PRECAUTIONS SHALL BE COMPLIED WITH PRIOR TO CONDUCTING WORK ON THE SYSTEM.

2.2.2. WORK PROCEDURE

WORK SHALL BE UNDERTAKEN UNDER A CONTROLLED PROCEDURE SO AS TO MINIMIZE THE RISK OF A FLAMMABLE GAS OR VAPOUR BEING PRESENT WHILE THE WORK IS BEING PERFORMED.

2.2.3. GENERAL WORK AREA

ALL MAINTENANCE STAFF AND OTHERS WORKING IN THE LOCAL AREA SHALL BE INSTRUCTED ON THE NATURE OF WORK BEING CARRIED OUT. WORK IN CONFINED SPACES SHALL BE AVOIDED. THE AREA AROUND THE WORK SPACE SHALL BE SECTIONED OFF. ENSURE THAT THE CONDITIONS WITHIN THE AREA HAVE BEEN MADE SAFE BY CONTROL OF FLAMMABLE MATERIAL.

2.2.4. CHECKING FOR PRESENCE OF REFRIGERANT

THE AREA SHALL BE CHECKED WITH AN APPROPRIATE REFRIGERANT DETECTOR PRIOR TO AND DURING WORK, TO ENSURE THE TECHNICIAN IS AWARE OF POTENTIALLY FLAMMABLE ATMOSPHERES. ENSURE THAT THE LEAK DETECTION EQUIPMENT BEING USED IS SUITABLE FOR USE WITH FLAMMABLE REFRIGERANTS, I.E. NO SPARKING, ADEQUATELY SEALED OR INTRINSICALLY SAFE.

2.2.5. PRESENCE OF FIRE EXTINGUISHER

IF ANY HOT WORK IS TO BE CONDUCTED ON THE REFRIGERATION EQUIPMENT OR ANY ASSOCIATED PARTS, APPROPRIATE FIRE EXTINGUISHING EQUIPMENT SHALL BE AVAILABLE TO HAND. HAVE A DRY POWDER OR CO2 FIRE EXTINGUISHER ADJACENT TO THE CHARGING AREA.

2.2.6. NO IGNITION SOURCES

NO PERSON CARRYING OUT WORK IN RELATION TO A REFRIGERATION SYSTEM WHICH INVOLVES EXPOSING ANY PIPE WORK THAT CONTAINS OR HAS CONTAINED FLAMMABLE REFRIGERANT SHALL USE ANY SOURCES OF IGNITION IN SUCH A MANNER THAT IT MAY LEAD TO THE RISK OF FIRE OR EXPLOSION. ALL POSSIBLE IGNITION SOURCES, INCLUDING CIGARETTE SMOKING, SHOULD BE KEPT SUFFICIENTLY FAR AWAY FROM THE SITE OF INSTALLATION, REPAIRING, REMOVING AND DISPOSAL, DURING WHICH FLAMMABLE REFRIGERANT CAN POSSIBLY BE RELEASED TO THE SURROUNDING SPACE. PRIOR TO WORK TAKING PLACE, THE AREA AROUND THE EQUIPMENT IS TO BE SURVEYED TO MAKE SURE THAT THERE ARE NO FLAMMABLE HAZARDS OR IGNITION RISKS. "NO SMOKING" SIGNS SHALL BE DISPLAYED.

2.2.7. VENTILATED AREA

ENSURE THAT THE AREA IS IN THE OPEN OR THAT IT IS ADEQUATELY VENTILATED BEFORE BREAKING INTO THE SYSTEM OR CONDUCTING ANY HOT WORK. A DEGREE OF VENTILATION SHALL CONTINUE DURING THE PERIOD THAT THE WORK IS CARRIED OUT. THE VENTILATION SHOULD SAFELY DISPERSE ANY RELEASED REFRIGERANT AND PREFERABLY EXPEL IT EXTERNALLY INTO THE ATMOSPHERE.

2.2.8. CHECKS TO THE REFRIGERATION EQUIPMENT

WHERE ELECTRICAL COMPONENTS ARE BEING CHANGED, THEY SHALL BE FIT FOR THE PURPOSE AND TO THE CORRECT SPECIFICATION. AT ALL TIMES THE MANUFACTURER'S MAINTENANCE AND SERVICE GUIDELINES SHALL BE FOLLOWED. IF IN DOUBT CONSULT THE MANUFACTURER'S TECHNICAL DEPARTMENT FOR ASSISTANCE. THE FOLLOWING CHECKS SHALL BE APPLIED TO INSTALLATIONS USING FLAMMABLE REFRIGERANTS:

- THE CHARGE SIZE IS IN ACCORDANCE WITH THE ROOM SIZE WITHIN WHICH THE REFRIGERANT CONTAINING PARTS ARE INSTALLED;
- THE VENTILATION MACHINERY AND OUTLETS ARE OPERATING ADEQUATELY AND ARE NOT OBSTRUCTED;
- IF AN INDIRECT REFRIGERATING CIRCUIT IS BEING USED, THE SECONDARY CIRCUIT SHALL BE CHECKED FOR THE PRESENCE OF REFRIGERANT;
- MARKING TO THE EQUIPMENT CONTINUES TO BE VISIBLE AND LEGIBLE. MARKINGS AND SIGNS THAT ARE ILLEGIBLE SHALL BE CORRECTED;
- REFRIGERATION PIPE OR COMPONENTS ARE INSTALLED IN A POSITION WHERE THEY ARE UNLIKELY TO BE EXPOSED TO ANY SUBSTANCE WHICH MAY CORRODE REFRIGERANT CONTAINING COMPONENTS, UNLESS THE COMPONENTS ARE CONSTRUCTED OF MATERIALS WHICH ARE INHERENTLY RESISTANT TO BEING CORRODED OR ARE SUITABLY PROTECTED AGAINST BEING SO CORRODED.

2.2.9. CHECKS TO ELECTRICAL DEVICES

REPAIR AND MAINTENANCE TO ELECTRICAL COMPONENTS SHALL INCLUDE INITIAL SAFETY CHECKS AND COMPONENT INSPECTION PROCEDURES. IF A FAULT EXISTS THAT COULD COMPROMISE SAFETY, THEN NO ELECTRICAL SUPPLY SHALL BE CONNECTED TO THE CIRCUIT UNTIL IT IS SATISFACTORILY DEALT WITH. IF THE FAULT CANNOT BE CORRECTED IMMEDIATELY BUT IT IS NECESSARY TO CONTINUE OPERATION, AN ADEQUATE TEMPORARY SOLUTION SHALL BE USED. THIS SHALL BE REPORTED TO THE OWNER OF THE EQUIPMENT SO ALL PARTIES ARE ADVISED. INITIAL SAFETY CHECKS SHALL INCLUDE:

- THOSE CAPACITORS ARE DISCHARGED: THIS SHALL BE DONE IN A SAFE MANNER TO AVOID POSSIBILITY OF SPARKING;
- THAT THERE NO LIVE ELECTRICAL COMPONENTS AND WIRING ARE EXPOSED WHILE CHARGING, RECOVERING OR PURGING THE SYSTEM; THAT THERE IS CONTINUITY OF EARTH BONDING.



WARNING

INSTALL THE UNIT IN ROOMS WHICH EXCEED 11 M². DO NOT INSTALL THE UNIT IN A PLACE WHERE INFLAMMABLE GAS MAY LEAK.



NOTE

THE MANUFACTURER MAY PROVIDE OTHER SUITABLE EXAMPLE OR MAY PROVIDE ADDITIONAL INFORMATION ABOUT THE REFRIGERANT ODOUR.

3. PRODUCT OVERVIEW

3.1. PRODUCT DIAGRAM

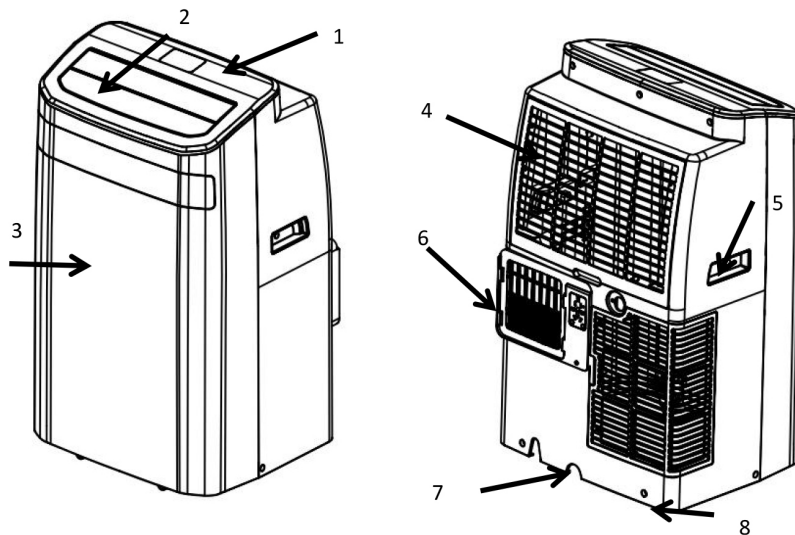

1	CONTROL PANEL	5	RECESSED HANDLE
2	AIR OUTLET	6	AIR EXHAUST
3	FRONT PANEL	7	DRAIN HOLE WITH SEALING PLUG
4	AIR INLET WITH AIR FILTER	8	CASTOR

NOTE: THE APPEARANCE IS ONLY FOR REFERENCE. PLEASE SEE THE REAL PRODUCT FOR DETAILED INFORMATION.

3.2. FEATURES

- ✓ HIGH CAPACITY IN A COMPACT SIZE WITH COOLING, DEHUMIDIFYING AND FAN FUNCTION.
- ✓ TEMPERATURE SETTING AND DISPLAY
- ✓ LED DIGITAL DISPLAY
- ✓ ELECTRONIC CONTROL WITH BUILT-IN TIMER, SLEEP MODE
- ✓ SELF-EVAPORATING SYSTEM FOR BETTER EFFICIENT
- ✓ AUTO SHUT OFF WHEN TANK FULL
- ✓ AUTOMATIC RESTART IN THE EVENT OF POWER OUTAGE
- ✓ AUTO DEFROSTING FUNCTION AT LOW AMBIENT TEMPERATURES
- ✓ REMOTE CONTROL
- ✓ 3- SPEED FAN
- ✓ CASTERS FOR EASY MOBILITY

4. INSTALLATION

4.1. UNPACKING

- UNPACK THE CARTON AND TAKE THE APPLIANCE AND ACCESSORIES OUT.
- CHECK THE DEVICE AFTER UNPACKING FOR ANY DAMAGE OR SCRATCHES ON IT.
- ACCESSORIES:

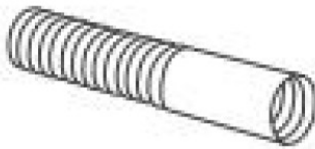

1. EXHAUST HOSE



2. HOSE CONNECTOR



3. WINDOW KIT ADAPTER

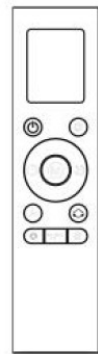

4. REMOTE CONTROL

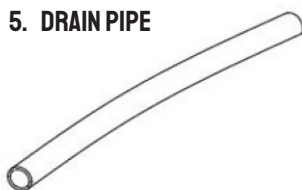

5. DRAIN PIPE



6. WINDOW KIT

4.2. CHOOSE YOUR LOCATION

- IF TIPPED MORE THAN 45°, ALLOW THE UNIT TO SET UPRIGHT FOR AT LEAST 24 HOURS BEFORE START UP.
- PLACE THE UNIT ON A FIRM, LEVEL SURFACE IN AN AREA WITH AT LEAST 50CM OF FREE SPACE AROUND IT TO ALLOW FOR PROPER AIR CIRCULATION.
- DO NOT OPERATE IN CLOSE PROXIMITY TO WALLS, CURTAINS, OR OTHER OBJECTS THAT MAY BLOCK AIR INLET AND OUTLET. KEEP THE AIR INLET AND OUTLET FREE OF OBSTACLES.
- NEVER INSTALL THE UNIT WHERE IT COULD BE SUBJECT TO:
 - HEAT SOURCES SUCH AS RADIATORS, HEAT REGISTERS, STOVES OR OTHER PRODUCTS THAT PRODUCE HEAT.
 - DIRECT SUNLIGHT
 - MECHANICAL VIBRATION OR SHOCK
 - EXCESSIVE DUST
 - LACK OF VENTILATION, SUCH AS CABINET OR BOOKCASE
 - UNEVEN SURFACE

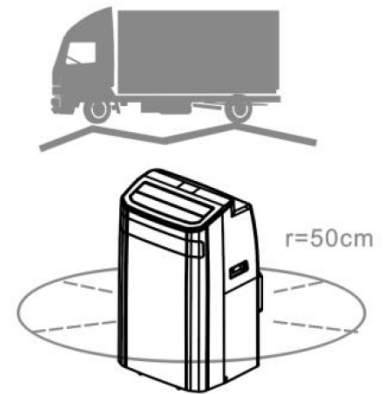

WARNING

INSTALL THE UNIT IN ROOMS WHICH EXCEED 11 M². DO NOT INSTALL THE UNIT IN A PLACE WHERE INFLAMMABLE GAS MAY LEAK.



NOTE

THE MANUFACTURER MAY PROVIDE OTHER SUITABLE EXAMPLE OR MAY PROVIDE ADDITIONAL INFORMATION ABOUT THE REFRIGERANT ODOUR.

4.3. ATTACH THE EXHAUST HOSE

THE AIR CONDITIONER REQUIRES BEING VENTED OUTSIDE SO THAT THE EXHAUST AIR CAN ESCAPE THE ROOM WHICH COMING FROM THE APPLIANCE CONTAINS WASTE HEAT AND MOISTURE.

DO NOT REPLACE OR EXTEND EXHAUST HOSE WHICH WILL RESULT IN DECREASED EFFICIENCY, EVEN WORSE SHUT DOWN THE UNIT DUE TO LOW BACK PRESSURE.

STEP 1

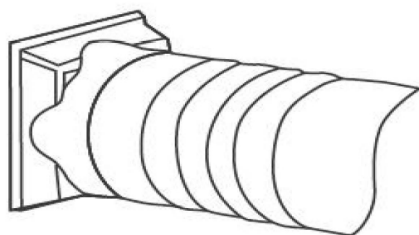

CONNECT THE HOSE CONNECTOR TO ONE END OF THE EXHAUST HOSE.

STEP 2

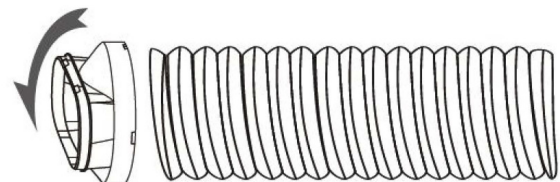

CONNECT THE WINDOWS KIT ADAPTER TO THE OTHER END OF THE EXHAUST HOSE.

STEP 3



EXTEND THE ADJUSTABLE WINDOW KIT THE LENGTH OF YOUR WINDOW. CONNECT THE EXHAUST HOSE TO THE WINDOW KIT.

STEP 4

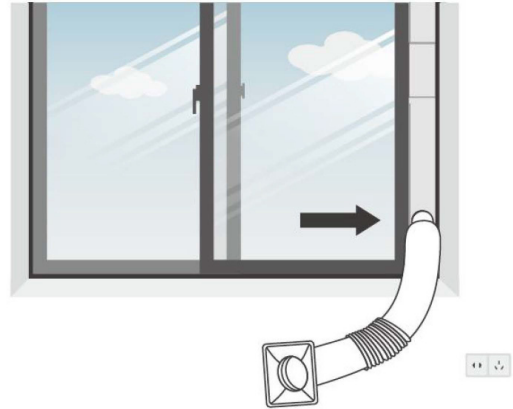

CLOSE YOUR WINDOW TO SECURE THE KIT IN PLACE. IT NEEDS TO HOLD THE WINDOW KIT FIRMLY IN PLACE, SECURE THE WINDOW KIT WITH DUCT TAPE IF REQUIRED. IT IS RECOMMENDED THAT THE GAP BETWEEN THE ADAPTER AND THE SIDES OF THE WINDOW SHOULD BE SEALED OFF FOR MAXIMUM EFFICIENCY.

STEP 5

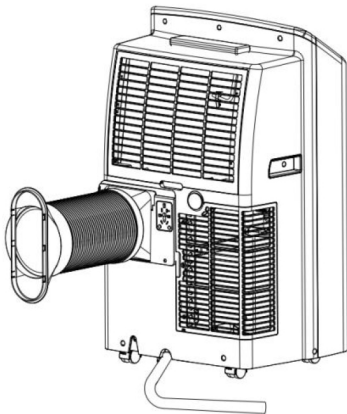

ATTACH THE HOSE CONNECTOR TO THE EXHAUST AIR OUTLET OF UNIT.

STEP 6



ADJUSTING THE LENGTH OF THE FLEXIBLE EXHAUST HOSE, AND AVOID BENDS IN THE HOSE. THEN PLACE AC NEAR AN ELECTRICAL OUTLET .

STEP 7

ADJUST THE LOUVER AT THE AIR OUTLET, AND THEN SWITCH ON THE UNIT.

5. OPERATION

5.1. CONTROL PANEL AND DISPLAY

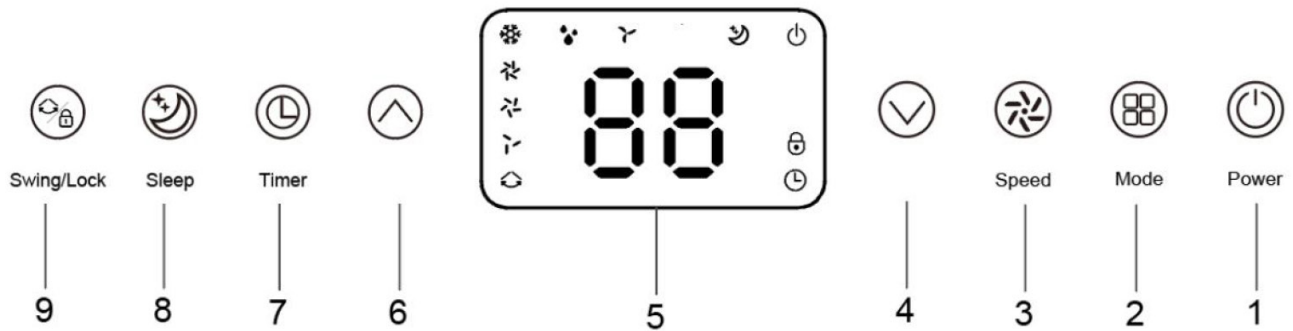

NO.	FUNCTION	DESCRIPTION
1	POWER	PRESS TO SWITCH THE MACHINE ON OR OFF
2	MODE	PRESS TO SWITCH THE OPERATION MODE BETWEEN COOL, DRY AND FAN.
3	SPEED	PRESS TO SWITCH THE FAN SPEED IN HIGH, MIDDLE AND LOW.
4	DOWN	DECREASING THE DESIRED TEMPERATURE (16°C - 32°C) OR TIMER SETTING.
5	DIGITAL DISPLAY	DISPLAYS FUNCTION SETTING AND TEMPERATURE.
6	UP	INCREASING THE DESIRED TEMPERATURE (16°C - 32°C) OR TIMER SETTING.
7	TIMER	PRESS TO SET TIMER, 1-24 HOURS, AND TURN ON OR OFF.
8	SLEEP	PRESS TO TURN SLEEP MODE ON OR OFF.
9	SWING/LOCK	AUTOMATICALLY ADJUST THE AIR FLOW DIRECTION VERTICALLY. LONG PRESS THIS BUTTON TO TURN ON OR TURN OFF CHILD-LOCK FUNCTION.

5.2. REMOTE CONTROL



5.3. SETTINGS

5.4.1. START-UP AND SHUTDOWN

- => PRESS POWER TO TURN THE UNIT ON. THE UNIT RUNS IN FAN AS DEFAULT.
- => PRESS MODE BUTTON TO SELECT THE DESIRED OPERATION MODE.
- => PRESS POWER AGAIN TO TURN OFF THE POWER.

5.4.2. OPERATION MODE

THE UNIT HAS THREE OPERATION MODES: COOL, DRY AND FAN.

A COOLING YOUR ROOM

SELECT THE COOL MODE TO LOWER THE TEMPERATURE IN YOUR ROOM.

- => PRESS MODE BUTTON REPEATEDLY UNTIL THE LED OF COOL OPERATION LIGHTS UP.
- => PRESS UP/DOWN BUTTON TO ADJUST THE TEMPERATURE WHICH IS DISPLAYED ON THE SCREEN. THE TEMPERATURE CAN BE SET BETWEEN 16°C AND 32°C.
- => PRESS SPEED BUTTON REPEATEDLY UNTIL THE DESIRED FAN SPEED INDICATOR LIGHTS UP.

TO CONTROL THE DIRECTION OF THE AIR FLOW HORIZONTALLY, PLEASE PRESS THE SWING BUTTON ON.



NOTE

THE AIR CONDITIONER STOPS IF THE ROOM TEMPERATURE IS LOWER THAN THE SELECTED TEMPERATURE.

B. VENTILATING YOUR ROOM

- => PRESS MODE BUTTON REPEATEDLY UNTIL THE LED OF FAN OPERATION LIGHTS UP. IN VENTILATION MODE THE ROOM AIR IS CIRCULATED, BUT NOT COOLED.
- => PRESS SPEED BUTTON REPEATEDLY TO SELECT THE FAN SPEED AS DESIRED.

C. DRYING YOUR ROOM

- => PRESS MODE BUTTON ON THE CONTROL PANEL OR REMOTE CONTROL, THE LED OF DRY OPERATION LIGHTS UP. THE FAN SPEED IS UNABLE TO SELECT. USER SHOULD CONNECT THE HOSE TO THE DRAIN OUTLET AT THE BOTTOM OF THE UNIT.

NOTE: IN THIS MODE, THE FAN SPEED SWITCHES OVER TO LOW SPEED AND CANNOT BE SELECTED.

D. SLEEP FUNCTION

THE SLEEP FUNCTION CAN BE ACTIVATED WHEN IN COOL MODE.

IN COOL MODE :

AFTER 1 HOUR THE PRESET TEMPERATURE IS INCREASED BY 1°C, AFTER ANOTHER HOUR THE PRESET TEMPERATURE WILL AGAIN BE INCREASED BY 1°C. ALL INDICATOR LIGHTS WILL DIM FOR REDUCED BRIGHTNESS, AND THE FAN SPEED WILL AUTOMATICALLY SWITCH TO LOW FOR QUIETER OPERATION. IN SLEEP MODE, THE UNIT WILL AUTOMATICALLY SWITCH OFF AFTER 12 HOURS.

5.4.3. TIMER SETTING (1 HOUR - 24 HOURS)

THE TIMER HAS TWO WAYS OF OPERATION:

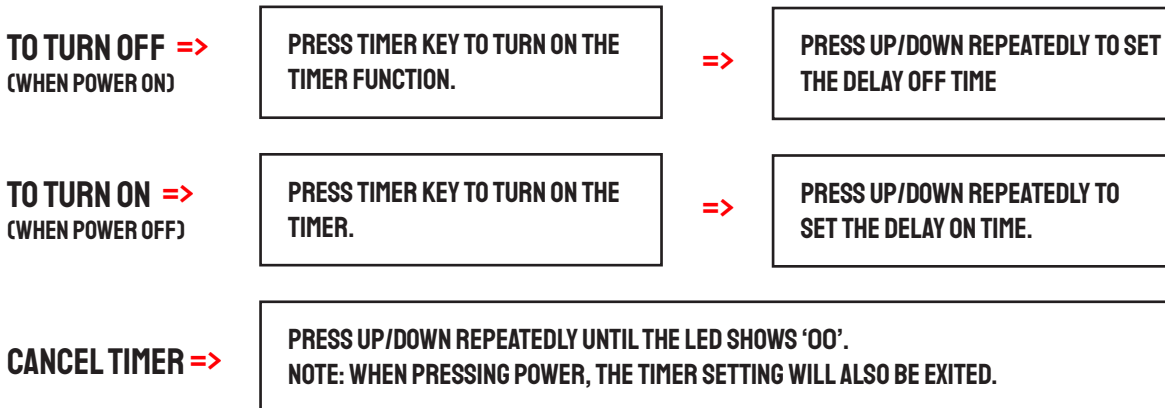

5.4.4. AUTOMATIC DEFROST

AT LOW ROOM TEMPERATURES, FROST MAY BUILD-UP AT THE EVAPORATOR DURING OPERATION. THE UNIT WILL AUTOMATICALLY START DEFROSTING AND THE POWER LED BLINKING. THE DEFROST CONTROL SEQUENCE IS AS FOLLOWS:

- A. WHEN THE UNIT OPERATES IN THE COOLING OPERATION, DRYING OPERATION, THE AMBIENT TEMPERATURE SENSOR SENSES THE EVAPORATOR COIL TEMPERATURE IS BELOW -1°C , AFTER THE COMPRESSOR WILL STOP OPERATING FOR 10 MINUTES OR THE COIL TEMPERATURE UP TO TC, THE UNIT RESTART TO COOL OPERATING MODE.
- B. WHEN THE UNIT OPERATES IN THE DRYING OPERATION, ONCE THE COIL TEMPERATURE SENSOR SENSES THE TEMPERATURE OF THE EVAPORATOR IS BELOW 40°C AND THE DIFFERENTIAL TEMPERATURE BETWEEN COIL TEMPERATURE AND ROOM TEMPERATURE IS BELOW 19°C AFTER THE COMPRESSOR OPERATION FOR 20 MINUTES, THE UNIT START DEFROSTING FOR 5 MINUTES AND THE POWER INDICATOR BLINKING.

5.4.5. OVERLOAD PROTECTION

IN THE EVENT OF A POWER LOSS, TO PROTECT THE COMPRESSOR THERE IS A 3-MINUTE DELAY UNTIL THE COMPRESSOR RESTARTING.

5.4. DRAINAGE

MANUAL DRAINAGE:

1. WHEN THE MACHINE STOPS AFTER THE WATER IS FULL, PLEASE UNPLUG THE POWER PLUG.
NOTE: PLEASE MOVE THE MACHINE CAREFULLY, SO AS NOT TO SPILL THE WATER IN THE WATER PAN AT THE BOTTOM OF THE BODY.
2. PLACE THE WATER CONTAINER BELOW THE SIDE WATER OUTLET BEHIND THE BODY.
3. UNPLUG THE WATER PLUG, THE WATER WILL AUTOMATICALLY FLOW INTO THE WATER CONTAINER.

NOTES:

1. KEEP THE WATER PLUG PROPERLY.
2. DURING DRAINAGE, THE BODY CAN BE TILTED SLIGHTLY BACKWARDS.
3. IF THE WATER CONTAINER CANNOT HOLD ALL THE WATER, BEFORE THE WATER CONTAINER IS FULL, STUFF THE WATER OUTLET WITH THE WATER PLUG AS SOON AS POSSIBLE TO PREVENT WATER FROM FLOWING TO THE FLOOR OR THE CARPET.

4. WHEN THE WATER IS DISCHARGED, STUFF THE WATER PLUG.

NOTE: RESTART THE MACHINE AFTER THE WATER PLUG AND DRAINAGE COVER ARE INSTALLED, OTHERWISE CONDENSATE WATER OF THE MACHINE WILL FLOW TO THE FLOOR OR THE CARPET.

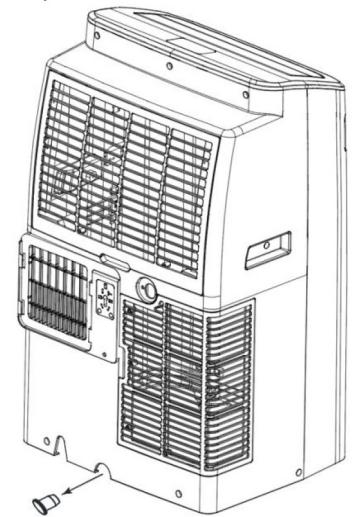

CONTINUOUS DRAINAGE

THE SELF-EVAPORATING SYSTEM USES THE COLLECTED WATER TO COOL THE CONDENSER COILS FOR BETTER EFFICIENT PERFORMANCE. IT IS NO NEED TO EMPTY THE DRAINAGE TANK IN COOLING OPERATION EXCEPT IN DRYING OPERATION AND HIGH HUMIDITY CONDITIONS. THE CONDENSATE WATER EVAPORATES AT THE CONDENSER AND EVACUATED THROUGH THE EXHAUST HOSE.

FOR CONTINUOUS OPERATION OR UNATTENDED OPERATING IN DRYING OPERATION, PLEASE CONNECT THE ATTACHED DRAIN HOSE TO THE UNIT. CONDENSATE WATER CAN BE AUTOMATICALLY FLOW INTO A BUCKET OR DRAIN BY GRAVITY.

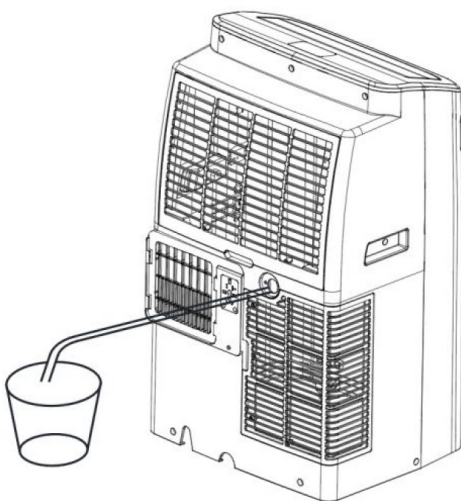

- SWITCH OFF THE UNIT BEFORE OPERATING.
- REMOVE THE PLUG OF THE WATER OUTLET OPENING, AND KEEP IT IN SAFE AREA.
- SECURELY AND PROPERLY CONNECT THE DRAIN HOSE AND MAKE SURE IT IS NOT KINKED AND CLEAR OF OBSTRUCTION.
- PLACE THE OUTLET OF HOSE OVER A DRAIN OR BUCKET AND ENSURE THAT WATER COULD FREELY FLOW OUT OF THE UNIT.
- DO NOT SUBMERGE THE END OF HOSE INTO WATER; OTHERWISE IT CAN CAUSE AN "AIR LOCK" IN THE HOSE.

TO AVOID WATER SPILLAGE:

- AS THE NEGATIVE PRESSURE OF CONDENSATE DRAIN PAN IS LARGE, TILT THE DRAIN HOSE DOWNWARD TOWARD THE FLOOR. IT IS APPROPRIATE THAT THE DEGREE OF INCLINATION SHOULD EXCEED 20 DEGREES.
- STRAIGHTEN THE HOSE TO AVOID A TRAP EXISTING IN THE HOSE

6. CLEANING AND CARE

6.1. CLEANING THE AIR FILTER (EVERY TWO WEEKS)

DUST COLLECTS ON THE FILTER AND RESTRICTS THE AIRFLOW. THE RESTRICTED AIRFLOW REDUCES THE EFFICIENCY OF THE SYSTEM AND IF IT BECOMES BLOCKED IT CAN CAUSE DAMAGE TO THE UNIT.

THE AIR FILTER REQUIRES REGULAR CLEANING. THE AIR FILTER IS REMOVABLE FOR EASY CLEANING. DO NOT OPERATE THE UNIT WITHOUT AN AIR FILTER, OR THE EVAPORATOR MAY BE CONTAMINATED.

1. PRESS POWER BUTTON TO SWITCH OFF THE UNIT AND UNPLUG THE POWER CORD.
2. REMOVE THE FILTER MESH FROM THE UNIT.
3. USE A VACUUM CLEANER TO SUCK DUST FROM THE FILTER.
4. TURN THE FILTER OVER AND RINSE THE AIR FILTER UNDER RUNNING WATER. LET THE WATER RUN THROUGH THE FILTER IN THE OPPOSITE DIRECTION OF AIR FLOW. SET ASIDE AND ALLOW THE FILTER TO AIR DRY COMPLETELY BEFORE REINSTALLING.

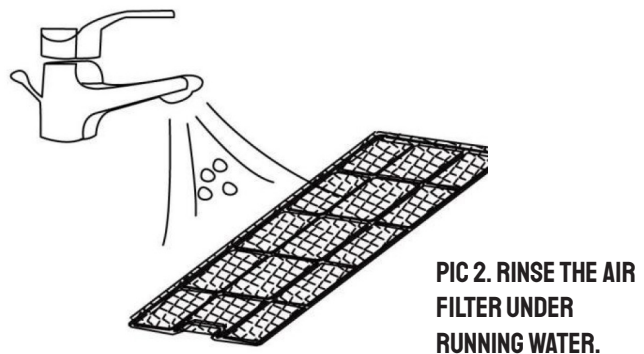
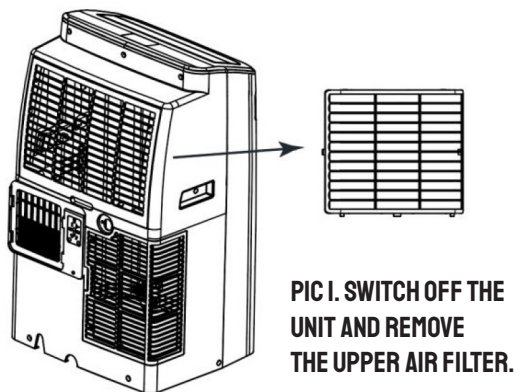

WARNING

TO PREVENT INJURY, DO NOT TOUCH THE EVAPORATOR SURFACE WITH BARE HANDS.

6.2. CLEANING UP OF REFRIGERANT

GENERAL MEASURES:

1. GAS/VAPOUR HEAVIER THAN AIR. MAY ACCUMULATE IN CONFINED SPACES, PARTICULARLY AT OR BELOW GROUND LEVEL.
2. ELIMINATE EVERY POSSIBLE SOURCE OF IGNITION.
3. USE APPROPRIATE PERSONAL PROTECTION EQUIPMENT (PPE).
4. EVACUATE UNNECESSARY PERSONNEL, ISOLATE, AND VENTILATE AREA.
5. DO NOT GET IN EYES, ON SKIN, OR ON CLOTHING. DO NOT BREATHE VAPOURS OR GAS.
6. PREVENT ENTRY TO SEWERS AND PUBLIC WATERS.
7. STOP THE SOURCE OF THE RELEASE, IF SAFE TO DO SO. CONSIDER THE USE OF WATER SPRAY TO DISPERSE VAPOURS.
8. ISOLATE THE AREA UNTIL GAS HAS DISPERSED. VENTILATE AND GAS TEST AREA BEFORE ENTERING. CONTACT COMPETENT AUTHORITIES AFTER A SPILL.

7. TROUBLESHOOTING

SYMPTOM	INSPECTION	SOLUTION
THE UNIT IS NOT OPERATING	CHECK THE POWER CONNECTION IS SECURE.	ENSURE THE POWER CORD IS FIRMLY PLUGGED INTO A SUITABLE WALL OUTLET.
	CHECK WHETHER THE WATER LEVEL INDICATOR IS ILLUMINATED.	EMPTY THE DRAIN PAN BY REMOVING THE RUBBER PLUG.
	CHECK THE ROOM TEMPERATURE.	THE UNIT OPERATES WITHIN A TEMPERATURE RANGE OF 5°C–35°C. ENSURE THE ROOM TEMPERATURE FALLS WITHIN THIS RANGE.
THE UNIT WORKS WITH REDUCED CAPACITY	CHECK WHETHER THE AIR FILTER IS DIRTY.	CLEAN THE AIR FILTER AS REQUIRED.
	CHECK IF THE AIR DUCT IS BLOCKED.	REMOVE ANY OBSTRUCTION FROM THE AIR DUCT.
	CHECK WHETHER DOORS OR WINDOWS ARE OPEN.	KEEP DOORS AND WINDOWS CLOSED DURING OPERATION.
	CHECK THAT THE CORRECT OPERATING MODE IS SELECTED AND TEMPERATURE IS SET PROPERLY.	SET THE CORRECT OPERATING MODE AND ADJUST THE TEMPERATURE ACCORDING TO THE USER MANUAL.
	CHECK WHETHER THE EXHAUST HOSE IS DETACHED.	ENSURE THE EXHAUST HOSE IS SECURELY ATTACHED.
WATER LEAKAGE	THE UNIT HAS BEEN MOVED WITHOUT EMPTYING THE WATER TANK.	EMPTY THE WATER TANK BEFORE TRANSPORTING THE UNIT.
	THE DRAIN HOSE IS KINKED OR BENT.	STRAIGHTEN THE DRAIN HOSE TO PREVENT WATER TRAPS OR BLOCKAGES.
EXCESSIVE NOISE	LOOSE OR VIBRATING PARTS.	TIGHTEN AND SECURE ANY LOOSE COMPONENTS.
	NOISE SIMILAR TO WATER FLOWING.	THE SOUND OF FLOWING WATER IS NORMAL AND IS CAUSED BY REFRIGERANT INSIDE THE UNIT.
ERROR CODE E0 – COMMUNICATION FAULT	COMMUNICATION ERROR BETWEEN THE MAIN PCB AND DISPLAY PCB.	CHECK THE WIRING HARNESS BETWEEN THE MAIN PCB AND DISPLAY PCB FOR DAMAGE.
ERROR CODE E1 – AMBIENT TEMPERATURE SENSOR FAILURE	FAULT WITH THE AMBIENT TEMPERATURE SENSOR.	CHECK THE SENSOR CONNECTION. REPLACE OR CLEAN THE TEMPERATURE SENSOR IF NECESSARY.
ERROR CODE E2 – COIL TEMPERATURE SENSOR FAILURE	FAULT WITH THE COIL TEMPERATURE SENSOR.	CHECK THE SENSOR CONNECTION. REPLACE OR CLEAN THE TEMPERATURE SENSOR IF NECESSARY.
ERROR CODE FT – CONDENSATE WATER HIGH LEVEL ALARM	WATER TANK IS FULL.	EMPTY THE DRAIN PAN BY REMOVING THE RUBBER PLUG.

8. DECOMMISSIONING

8.1. STORAGE

LONG-TERM STORAGE - IF YOU WILL NOT BE USING THE UNIT FOR AN EXTENDED PERIOD OF TIME (MORE THAN A FEW WEEKS) IT IS BEST TO CLEAN THE UNIT AND DRY IT OUT COMPLETELY. PLEASE STORE THE UNIT PER THE FOLLOWING STEPS:

1. UNPLUG THE UNIT AND REMOVE EXHAUST HOSE AND WINDOW KIT STORE WITH THE UNIT.
2. DRAIN THE REMAINING WATER FROM THE UNIT.
3. CLEAN THE FILTER AND LET THE FILTER DRY COMPLETELY IN A SHADED AREA.
4. COLLECT THE POWER CORD AT THE WATER TANK.
5. RE-INSTALL THE FILTER AT ITS POSITION.
6. THE UNIT MUST BE KEPT IN UPRIGHT POSITION WHEN IN STORAGE.
7. PRESERVING THE MACHINE IN VENTILATING, DRY, NON-CORROSIVE GAS AND SAFE PLACE INDOOR.

ATTENTION!



BEFORE PACKAGING THE UNIT, THE INTERNAL EVAPORATOR MUST BE COMPLETELY DRIED TO PREVENT COMPONENT DAMAGE AND MOULD GROWTH. UNPLUG THE APPLIANCE AND PLACE IT IN A DRY, WELL-VENTILATED AREA FOR SEVERAL DAYS TO ALLOW IT TO DRY THOROUGHLY. ALTERNATIVELY, YOU CAN SWITCH THE UNIT ON AND SET IT TO LOW FAN (VENTILATION) MODE. ALLOW IT TO RUN IN THIS MODE UNTIL THE DRAINAGE PIPE IS FULLY DRY. THIS WILL HELP REMOVE INTERNAL MOISTURE, KEEP THE INTERIOR DRY, AND PREVENT MILDEW FROM FORMING.

8.2. DISPOSAL OF ELECTRICAL EQUIPMENT (WEEE)

THIS PRODUCT MUST NOT BE DISPOSED OF WITH HOUSEHOLD WASTE.

IN ACCORDANCE WITH THE UK WASTE ELECTRICAL AND ELECTRONIC EQUIPMENT (WEEE) REGULATIONS, ELECTRICAL PRODUCTS MUST BE COLLECTED SEPARATELY FOR PROPER TREATMENT, RECOVERY AND RECYCLING.

THE SYMBOL OF A CROSSED-OUT WHEELED BIN ON THE PRODUCT OR PACKAGING INDICATES THAT THE APPLIANCE SHOULD NOT BE DISPOSED OF WITH GENERAL HOUSEHOLD WASTE.

PLEASE TAKE THIS PRODUCT TO A DESIGNATED COLLECTION POINT FOR THE RECYCLING OF ELECTRICAL AND ELECTRONIC EQUIPMENT. FOR INFORMATION ON AVAILABLE COLLECTION AND RECYCLING SCHEMES, CONTACT YOUR LOCAL AUTHORITY OR WASTE DISPOSAL SERVICE.

IMPROPER DISPOSAL MAY RESULT IN HAZARDOUS SUBSTANCES ENTERING THE ENVIRONMENT, WHICH COULD POSE RISKS TO HUMAN HEALTH AND WILDLIFE.



9. WARRANTY TERMS

9.1. COVERAGE

24-MONTH LIMITED PARTS WARRANTY AGAINST MANUFACTURING DEFECTS FROM DATE OF PURCHASE.

YOUR AIR CONDITIONER WAS MANUFACTURED AT FACILITIES MEETING ENVIRONMENTAL STANDARDS. PLEASE HAVE INSTALLATION PERFORMED BY AUTHORISED SERVICE. WARRANTY MAY BECOME VOID IF INSTALLED BY UNAUTHORISED THIRD PARTIES.

9.2. WARRANTY CONDITIONS

THIS WARRANTY PROVIDED BY THE MANUFACTURER DOES NOT COVER REPAIR OF MALFUNCTIONS CAUSED BY ABNORMAL USE, AND THE FOLLOWING ARE EXCLUDED FROM WARRANTY:

- MALFUNCTIONS AND DAMAGE DURING USE BY OPERATOR
- DAMAGE DURING SHIPPING, LOADING, UNLOADING AFTER DELIVERY TO END USER
- DAMAGE DUE TO LOW/HIGH VOLTAGE NOT MATCHING RATING PLATE
- DAMAGE DUE TO ELECTRICAL INSTALLATION ISSUES
- DAMAGE FROM FIRE OR LIGHTNING
- MALFUNCTIONS FROM USE CONTRARY TO USER MANUAL INSTRUCTIONS
- UNAUTHORISED REPAIRS OR MODIFICATIONS
- IMPROPER INSTALLATION
- WATER DAMAGE FROM INCORRECT CLEANING
- PLUMBING ISSUES OR HARD WATER DAMAGE
- NORMAL WEAR INCLUDING COMPONENT AGING

REPAIRS OF ABOVE MALFUNCTIONS ARE NOT COVERED BY WARRANTY – REPAIR WILL BE CHARGED.

PRODUCT SHIPPING TO USE LOCATION AND INSTALLATION ARE NOT INCLUDED IN PRODUCT PRICE.

RESPONSIBILITY FOR ISSUING AND VALIDATING WARRANTY CERTIFICATE BELONGS TO THE SELLER, DEALER, AGENCY, OR REPRESENTATIVE FROM WHOM THE CONSUMER PURCHASED THE PRODUCT.

WARRANTY IS VALID ONLY FOR MALFUNCTIONS OCCURRING WITHIN WARRANTY PERIOD. NO OTHER CLAIMS FOR REFUNDS, REPAIRS, OR REPLACEMENTS CAN BE MADE.

IF DESTRUCTION/FALSIFICATION OF ORIGINAL SERIAL NUMBER ON WARRANTY CERTIFICATE OR PRODUCT IS DETECTED, PRODUCT WILL BE OUT OF WARRANTY.

FOR WARRANTY REPAIRS, ONLY AUTHORISED SERVICES SPECIFIED IN WARRANTY CERTIFICATE OR ON WEBSITE ARE AUTHORISED.

USE ONLY AS INTENDED. OPERATE SAFELY. MAINTAIN REGULARLY.

SAVE THIS USER MANUAL FOR FUTURE REFERENCE



AAC009 · CONTENDER PORTABLE AIR CONDITIONER



STEP UP TO THE PLATE

Distributed by RG Distributors Ltd | Unit 7 Jade Business Park | Spring Road | Seaham | SR7 9DR

SERVICE & SUPPORT:  **0333 358 3678**  **sales@ecatering.co.uk**

Office Hours: Mon - Fri 9:00AM - 5:00PM (excluding public holidays)